

SQUARE RUBBER FENDER

DIMENSIONS SPECIFICATIONS

Superior Guarantee, Supreme Guard

NANHAI is the international leading marine fender manufacturer with 20 years in fender production. NANHAI Rubber Fender design and manufacture according to PIANC 2002.

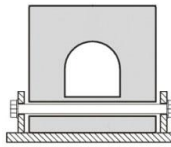

Square Rubber Fender (SD) Dimension Specifications

SPEC.	A (mm)	B (mm)	C (mm)	D (mm)	ΦE (mm)	ΦF (mm)	G (mm)	H (mm)	Bolt Size
SD100	100	100	50	45	30	15	90-130	200-300	M12
SD150	150	150	70	65	40	20	110-150	250-300	M16
SD165	165	125	80	60	40	20	110-150	250-300	M16
SD200	200	150	90	65	50	25	130-180	300-400	M20
SD200	200	200	90	95	50	25	130-180	300-400	M20
SD250	250	200	120	95	60	30	140-200	350-450	M24
SD250	250	250	120	120	60	30	140-200	350-450	M24
SD300	300	250	140	115	60	30	140-200	350-450	M24
SD300	300	300	125	135	60	30	140-200	350-450	M24
SD400	400	400	200	200	75	35	140-200	350-450	M30
SD500	500	500	250	250	90	45	160-230	400-500	M36

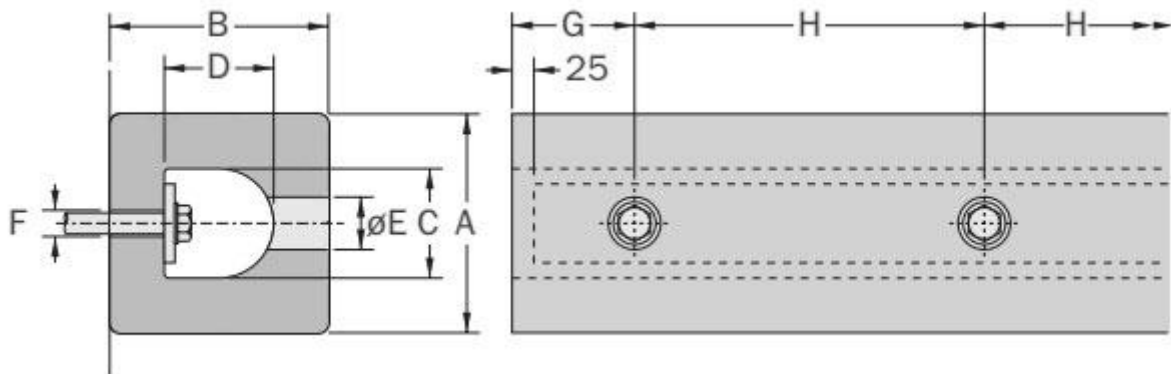

SHANDONG NANHAI AIRBAG ENGINEERING CO.,LTD.

NO.5608 Shuangshan North Road,Zhangqiu District,Jinan City, Shandong,China.

www.nhfoamfender.com | + 86 531-88723323 | info@airbag.cc

SQUARE RUBBER FENDER

DIMENSIONS SPECIFICATIONS

Superior Guarantee, Supreme Guard

NANHAI is the international leading marine fender manufacturer with 20 years in fender production. NANHAI Rubber Fender design and manufacture according to PIANC 2002.

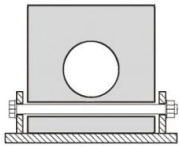

Square Rubber Fender (SO) Dimension Specifications

SPEC.	A (mm)	B (mm)	ΦC (mm)	ΦD (mm)	E (mm)	F (mm)	G (mm)	H (mm)	Bolt Size
SO100	100	100	30	15	25	10	90-130	200-300	M12
SO150	150	150	65	20	30	12	110-150	250-350	M16
SO165	165	125	65	20	30	15	110-150	250-350	M16
SO200	200	200	75	25	45	15	130-180	300-400	M20
SO200	200	200	100	25	40	15	130-180	300-400	M20
SO250	250	200	80	30	45	20	140-200	350-450	M24
SO250	250	250	100	30	50	20	140-200	350-450	M24
SO300	300	250	100	30	50	25	140-200	350-450	M24
SO300	300	300	125	30	60	25	140-200	350-450	M24
SO350	350	350	150	35	65	25	140-200	350-450	M30
SO350	350	350	175	35	65	25	140-200	350-450	M30
SO400	400	400	200	35	70	30	140-200	350-450	M30
SO500	500	500	250	45	90	40	150-230	400-500	M36

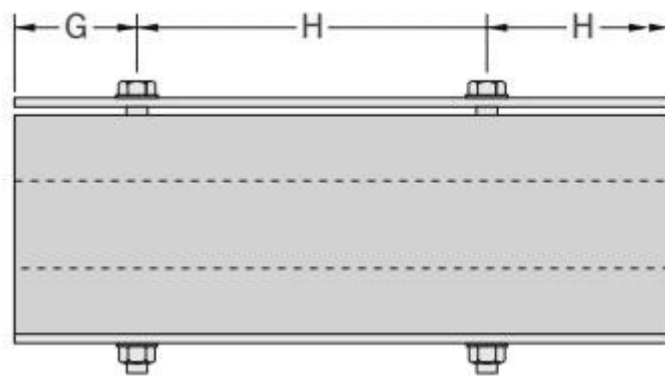
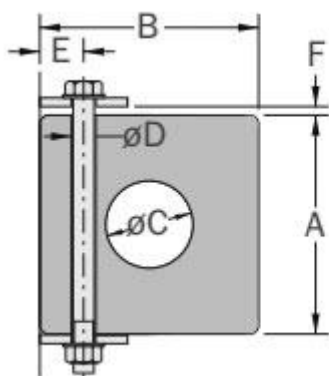

SHANDONG NANHAI AIRBAG ENGINEERING CO.,LTD.

NO.5608 Shuangshan North Road,Zhangqiu District,Jinan City, Shandong,China.

www.nhfoamfender.com | + 86 531-88723323 | info@airbag.cc